

**Installation, Operation and Maintenance Manual**

**WKM<sup>®</sup> SAF-T-SEAL<sup>®</sup>  
API 6D GATE VALVES**



**WKM<sup>®</sup>**

**TABLE OF CONTENTS****WKM SAF-T-SEAL  
API 6D GATE VALVES**

## Bill of Materials

2 inch - 4 inch Model M .....	1
6 inch - 12 inch Model C3/C6 .....	2
6 inch - 12 inch Class 300 - 900 Model C6B .....	3
6 inch - 12 inch Class 1500 - 2500 and 14 inch - 36 inch Class 300 - 900 Model C2B/C2C.....	4
Scope .....	5
Nameplate Information .....	5
Storage .....	6
Installation .....	6
Hydrostatic Testing .....	7
Operation .....	8
Routine Maintenance .....	9
Draining Valve .....	9
Low Temperature Precautions .....	10
Lubricating Handwheel and Operator Assembly.....	13
Lubricating Seats .....	13
Recommended Lubricants and Sealants .....	14
Maintaining Vee-Packing .....	16
Trouble Shooting Chart .....	17

### Valve Details - 2 inch - 4 inch Model M

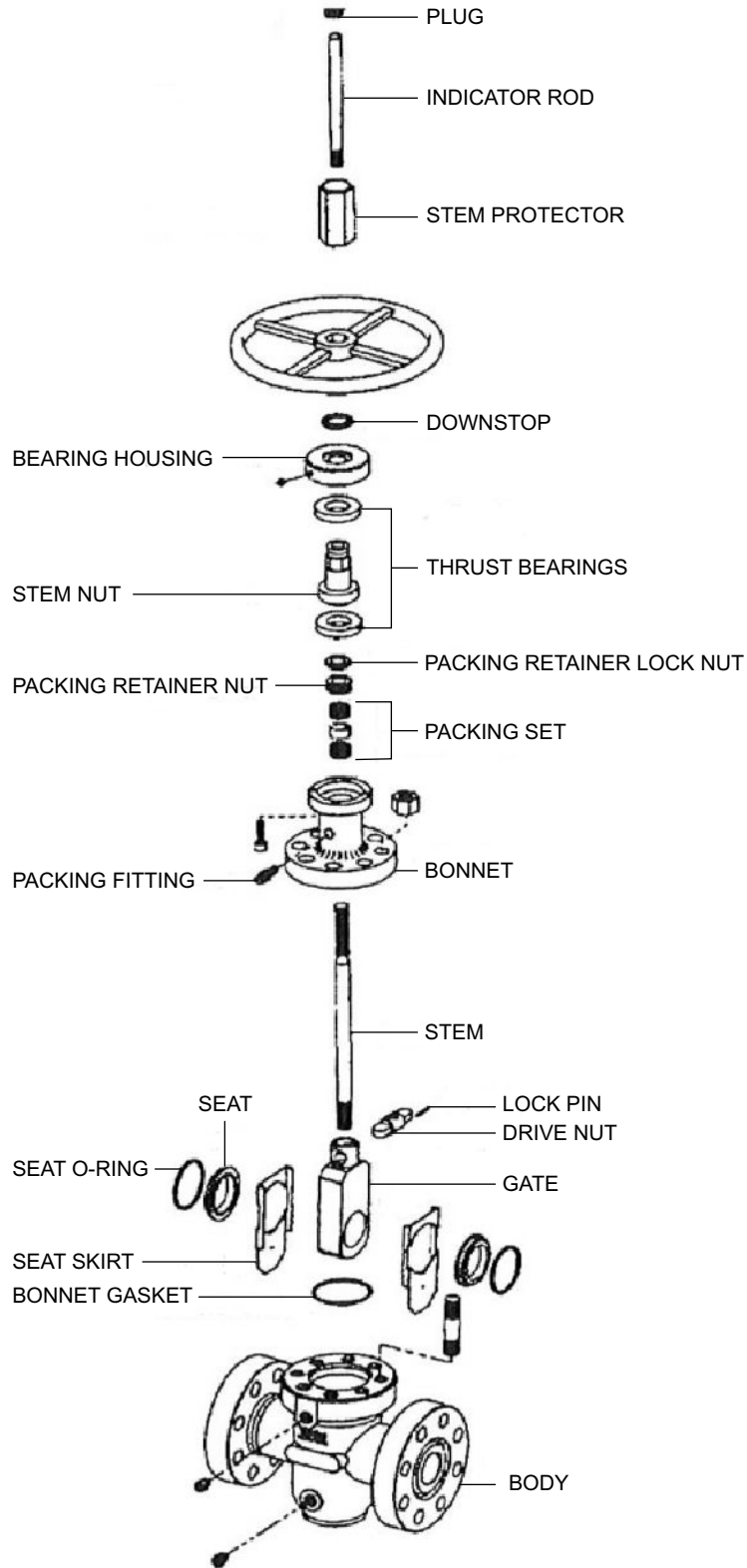

Figure 1 - WKM Saf-T-Seal Gate Valve 2" - 4" Class 300-1500 (Model M)  
 Details may vary by size

### Valve Details - 6 inch - 12 inch Class 300-900 Model C6B

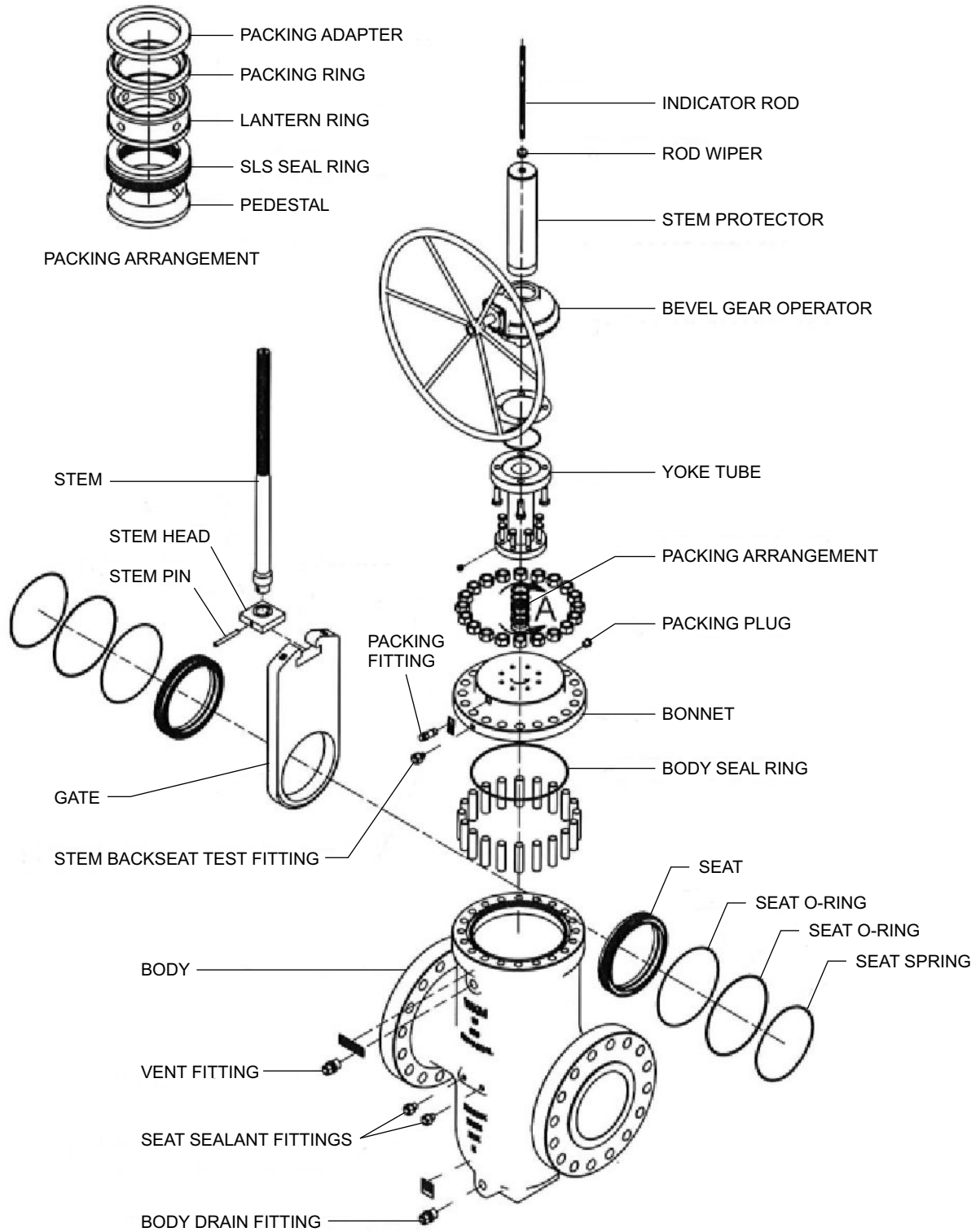

Figure 3 - WKM Saf-T-Seal Gate Valve 6" - 12" Class 600 - 900 (Model C6B)  
 Details may vary by size

### Valve Details - 6 inch - 12 inch Model C3/C6

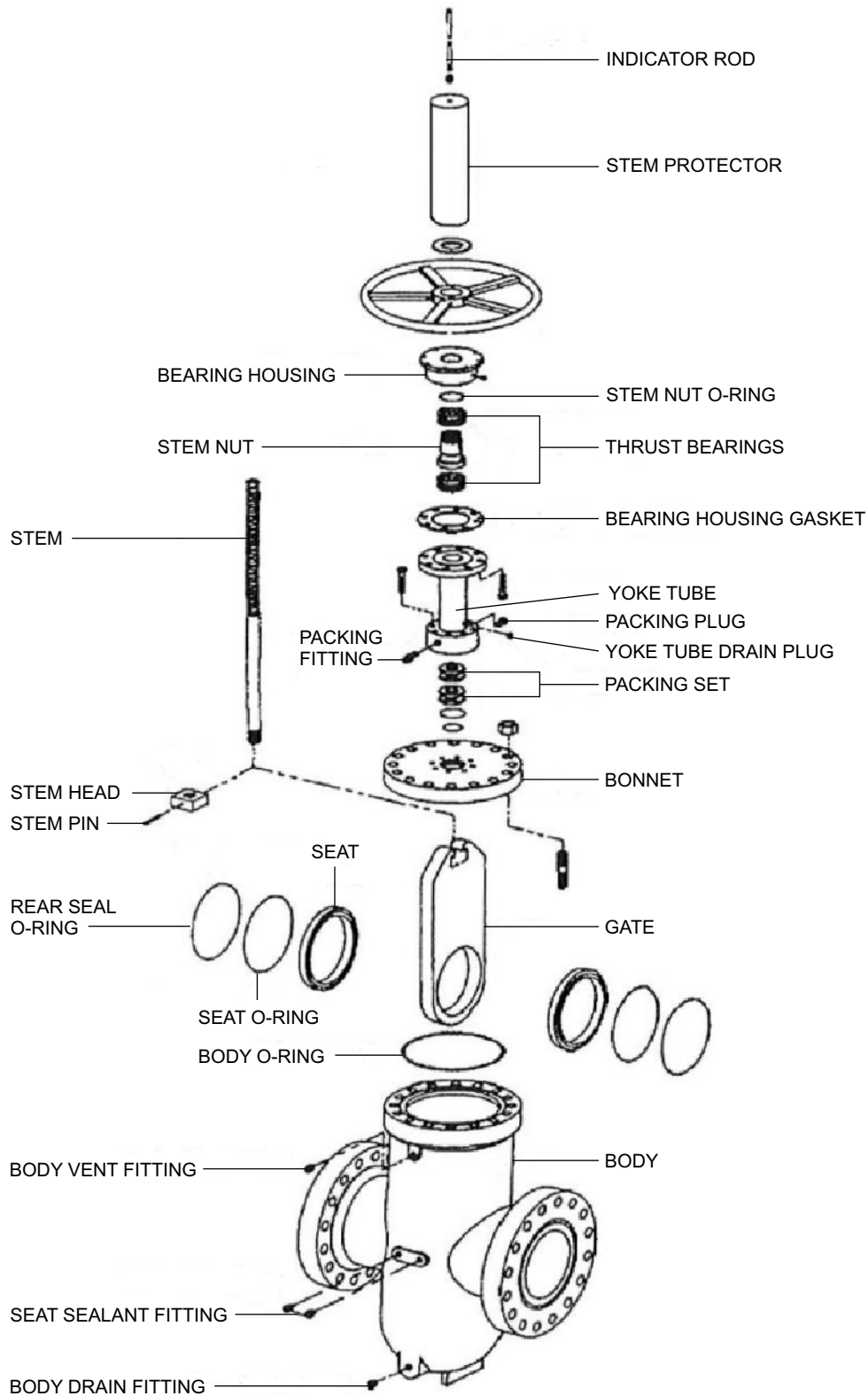

Figure 2 - WKM Saf-T-Seal Gate Valve 6" - 12" Class 150-900 (Model C3/C6)  
 Details may vary by size

**Valve Details - 6 inch - 12 inch Class 1500 - 2500  
14 inch - 36 inch Class 300 - 900 Model C2B/C2C**

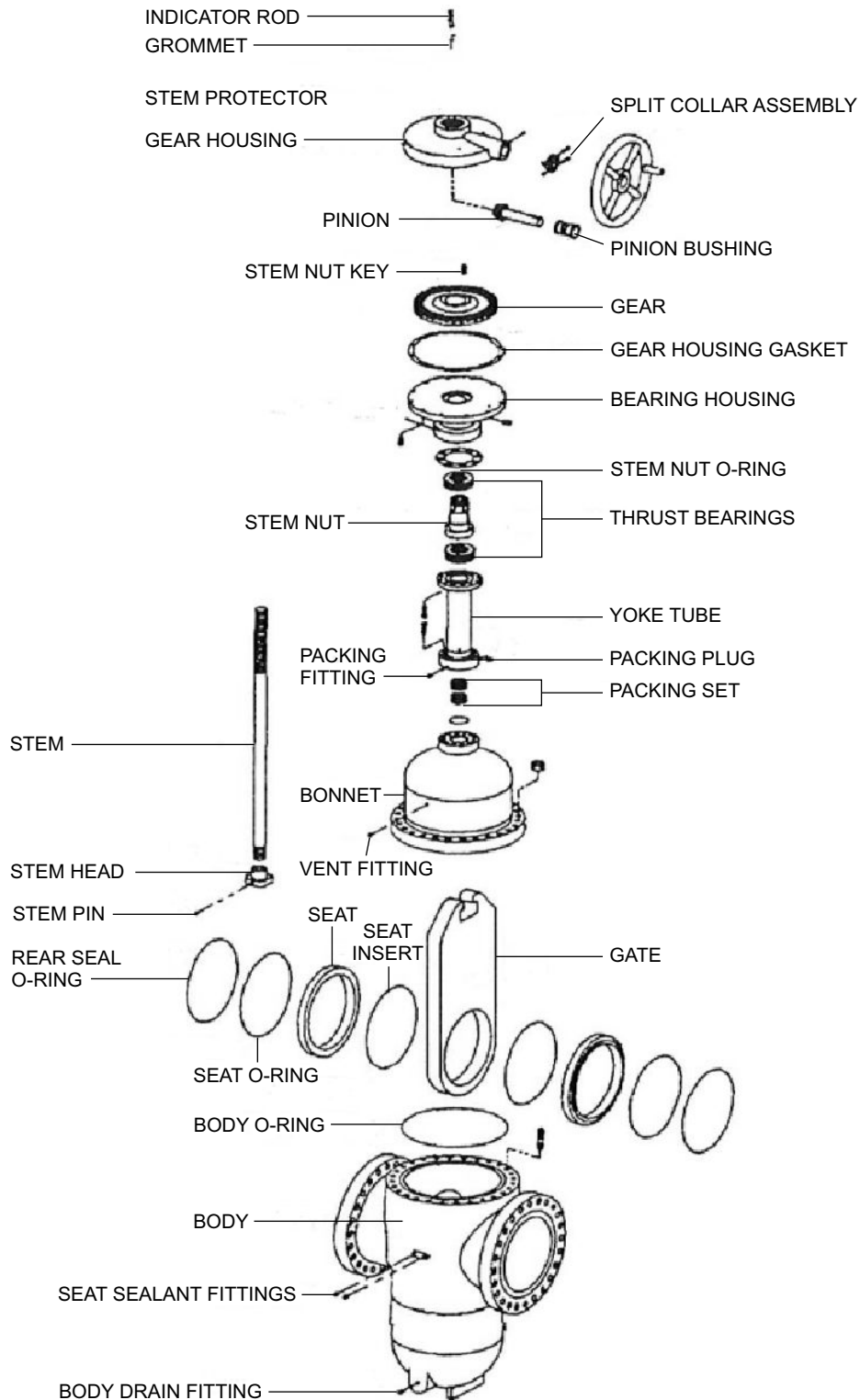

Figure 4 - WKM Saf-T-Seal Gate Valve 6" - 12" Class 1500 - 2500, 14" - 36" (Model C2B/C2C)  
Details may vary by size

### Scope

This manual covers all bolted bonnet Saf-T-Seal gate valves. Drawings, shown are typical. The design of specific valves may vary slightly from the drawings.

The Saf-T-Seal gate valve is a simple, yet rugged and reliable, through conduit gate valve. It utilizes two floating seats to provide a complete seal with the gate. The full bore design has the same pressure drop as an equivalent length of pipe and allows passage of all types of scrapers (pigs). The valve stroke is established by manufacturing tolerances and cannot get out of adjustment. The valve can be repaired while in line (pressure removed and valve drained).

The stem is sealed either by Chevron packing or spring-loaded lip seals. In an emergency, plastic packing can be injected into the packing box to affect a temporary seal while the valve is under pressure.

Saf-T-Seal valves do not depend on lubricant for a seal in normal operation. However, lubricants/sealants can be injected to promote smooth operation (most 6" and larger sizes). Seat sealant can also be injected to affect a seal in an emergency should the seats become damaged by foreign matter. Seats with all metal seats are available in special trims.

Excess body pressure is automatically vented to the upstream conduit by the seat. External body cavity relief systems are not required.

Saf-T-Seal gate valves are available in sizes, pressure classes, materials, and coatings to meet industry requirements. Valves are available with Lubrication1 Packing/Drain extensions and Stem/Yoke tube extensions.

### Nameplate Information

**ITEM STAMP**

- 1 Nominal Valve Size
- 2 Maximum Cold Working Pressure (psig)
- 3 \*Serial Number
- 4 API Class Designation
- 5 Maximum Temperature in °F
- 6 \*Bill of Material Number
- 7 Body Material Designation
- 8 Stem Material Designation
- 9 Gate Material Designation
- 10 Seat Material Designation
- 11 (Maximum Operating Pressure at 250°F - if Applicable)
- 12 (API Monogram - if Applicable)
- 13 Model Designation
- 14 (Marking for Non-Standard End-to-End - if Applicable)
- 15 (Licence Number - if Applicable)
- 16 Date of Manufacture
- 17 (Impact Test Temperature - if Applicable)

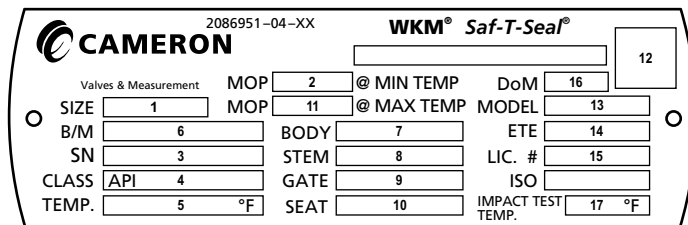

( ) Description in parenthesis may be left blank in some cases.

\* Most important data for obtaining replacement parts. Nameplate may vary.

## Storage

After WKM Saf-T-Seal Gate Valves are assembled and tested, the valves are left in the full open position, seats and bores are greased and end protectors are installed. These measures will provide protection for approximately six months. The following care should be taken when storing valves:

1. Make sure the valve end connection covers remain in place during storage.

2. If the valve does not have an operator and the valve will be stored outside, the exposed stem or the stem adapter should be covered to avoid accumulation of water and debris.

If long-term storage is required, the valve should be conditioned by the following Cameron procedure X-150771-01. Ensure adequate end connection covers are in place. Request a copy of X-150771-01 from Cameron Valves & Measurement group.

---

## Installation

WKM Saf-T-Seal Gate Valves are bi-directional and have no preferred pressure end. Overhaul and repair is easier with valve in the "stem vertical" position. When handling or installing the valve, keep the valve in the full open position whenever possible to prevent foreign matter damage to the gate and seat sealing surfaces. The valve should be lifted in such a way that the body supports the load or use lifting lugs, if provided.

---

**CAUTION: Do not use handwheels or other protruding parts of the valve, gearbox, or actuator to lift the valve. During handling, use care to avoid damaging the end connection faces, fittings and bypass relief systems. The end connection necks are suitable places to attach lifting slings, if lifting lugs are not provided on the valve.**

---

**Flange End Valves** may be bolted into line using two open boxed end wrenches. Power wrenches may be required for larger

valves. Make sure the line flanges are properly aligned and will not distort or bind the valve. Use new flange gaskets.

1. Bolt and nut threads should be lubricated to obtain proper loading of bolts.
2. Finger-tighten all nuts first.
3. Tighten bolts, using the crisscross method and torque each bolt to ASME or gasket manufacturer's specification.

**Butt Weld End Valves** should be welded into the line by qualified welders, using qualified procedures. Cameron's Valves & Measurement group recommends that all welding procedures and welders be qualified per ASME Section IX.

---

**CAUTION: Keep weld end valves open while installing/welding into the line. Weld slag created during the welding process could damage gate sealing surfaces.**

---



## Installation Continued

1. Use solvent to clean grease or rust inhibitor from the gate and/or bore of the valve.
2. Make sure the line and valve weld bevels are properly aligned and will not bind the valve.
3. Electric welding equipment is preferred for all installations. However, if only oxygen-acetylene welding equipment is available, extreme caution should be taken regarding excess welding temperature to prevent damage to sealing components of the valve.
4. Weld with the gate in "Full Open" position.
5. Make sure temperature of the body/seat area does not exceed 250°F. (Check with Tempil stick or equivalent).
6. Avoid rapid application of excess welding material. Weld each end of the valve with a continuous bead using a 1/8" maximum diameter electric welding rod.
7. Keep the valve in the "Full Open" position until the line has been thoroughly cleaned of weld slag in the valve bore and line (by pigging and/or flushing) before changing the position of the gate.

---

## Hydrostatic Testing

When WKM Saf-T-Seal Gate Valves are installed in a piping system that requires hydrostatic testing of the adjoining pipe, follow these procedures to minimize any damage that could occur to the sealing surface and seat seals inside the valve.

---

**CAUTION: Ensure that all test fluids contains corrosion inhibitors and these are compatible with the valve seat and seal materials.**

---

1. The valve should be in the fully open position when the injection of test fluids begins. This will allow any pipeline debris to be flushed through the valve bore and out of the piping.

2. Once the piping system has been purged of debris and the system has been filled completely with the test fluid, the gate should be placed in the partially open position to allow test fluid into the body cavity of the valve.
3. The valve is now ready to be hydrostatically pressure tested.

---

**CAUTION: Do not exceed pressures listed on the following page. The maximum Allowable Working Pressure (MAOP) is marked on the nameplate.**

---

## Hydrostatic Testing Continued

Pressure Class	Hydrostatic Shell		Hydrostatic Seat	
	psig	(barg)	psig	(barg)
150	425	(31)	325	(22)
300	1125	(78)	825	(57)
600	2250	(155)	1650	(114)
900	3375	(233)	2475	(171)
1500	5625	(389)	4125	(284)
2500	9375	(646)	6875	(474)

4. Upon completion of hydrostatic testing, the valve should be returned to the fully open position before removing the test fluid from the piping system. The test fluid in the body cavity can be drained through the body drain port located in the lower portion of the valve. (See Draining Valve Page 9).
5. Close the valve body bleed fitting and return the valve to required operating position, either fully open or fully closed.
6. If the valve is equipped with seat injection fittings, the valve seat pockets should be filled with an approved valve lubricant to displace any test fluid from behind the seats.
7. WKM T-11 or T-102 trim valves having Vee-Packing shall be repacked after hydrostatic testing with water. Follow the procedure in the Troubleshooting section of this manual for repacking the stem seal. Use WKM #113 or Jim Ray Tiger Pak FF plastic packing.

## Operation

The WKM Saf-T-Seal Gate Valve may be operated with a handwheel or may be power actuated. With either mode of actuation, open and close valve completely. **DO NOT THROTTLE FLOW.**

The valve, in good condition, will seal pressure up to the maximum allowable working pressures as a block valve, single-block-and-bleed valve or a double-block-and-bleed valve.

Valves equipped with handwheels are CLOSED by turning the handwheel CLOCKWISE until a stop is felt. The indicator rod at the top of the valve will move down (towards the valve bore), as the handwheel is turned CLOCKWISE.

The valve is OPENED by turning the handwheel COUNTER-CLOCKWISE until it contacts the stop. The indicator rod at the top of the valve will move up (away from the valve bore), as the handwheel is turned COUNTER-CLOCKWISE.

When valves are equipped with power actuators, the movement of the indicator rod will indicate if the valve is being opened or closed. Make sure all accessories recommended by the actuator manufacturer are installed before valve actuator installation. Should any maintenance be necessary, obtain the part number from the unit's nameplate and contact Cameron's Valves & Measurement group or the nearest representative.

## Routine Maintenance

The following outlines the minimum scheduled maintenance required for WKM Saf-T-Seal Gate Valves to promote trouble-free service and long life. Some applications may require more maintenance. Visually inspect every six (6) months.

See trouble shooting section (Page 17) for temporary solutions to problems.

Operate the valve once a month, if practical. A full open-closed cycle is preferable. Operate a partial cycle as a minimum.

---

**CAUTION: Verify compatibility of any sealant, lubricant, or anti-freeze with the trim of the valve and product in the line.**

---

---

## Draining Valve

After lengthy service, there is a possibility of water, line scale, sediment or other foreign matter collecting in the lower body cavity. It is advisable to periodically drain the valve to discourage development of conditions that can possibly lead to valve damage or impair the operation of the valve. If draining is not regularly scheduled, it is strongly recommended to drain the valve at these times:

1. After hydrostatic testing.
2. After cleaning the line.
3. When valve cannot be fully opened or closed. (Foreign matter in the bottom of valve can not only prevent placing valve in a fully closed position, it can also cause permanent damage to the internal sealing surfaces).

A safety pressure releasing tool is required to simplify the procedure of releasing body pressure or draining the valve. To release body pressure or to drain valve, first place the valve in the closed position.

---

**WARNING: To avoid possibly being struck by liquid or foreign solid matter, position yourself so the outlet port of the grease fitting is pointing safely away from you. (If the ball check is not holding pressure, pressure will blow through the safety holes in the cap.) Back-up the seat grease fitting using a wrench so only the safety cap will be removed from the fitting. Carefully remove the safety cap from the seat grease fitting. NEVER remove the grease fitting with the valve under pressure!**

---

### Draining Valve Continued

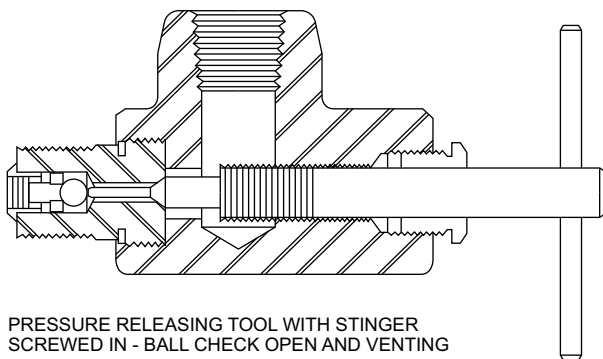

PRESSURE RELEASING TOOL WITH STINGER SCREWED IN - BALL CHECK OPEN AND VENTING

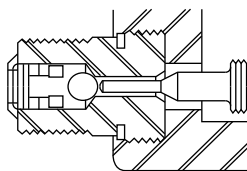

PRESSURE RELEASING TOOL AS INSTALLED - BALL CHECK CLOSED

Pressure releasing Tool

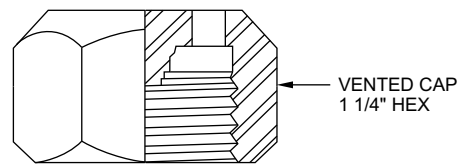

VENTED CAP  
1 1/4" HEX

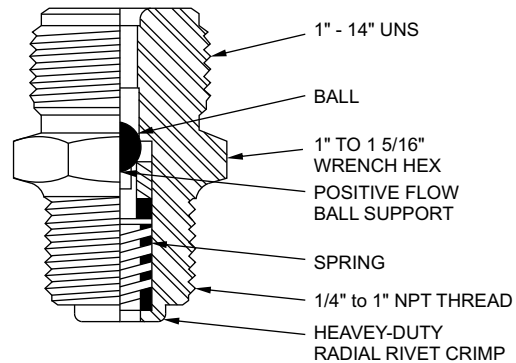

1" - 14" UNS  
BALL  
1" TO 1 5/16" WRENCH HEX  
POSITIVE FLOW BALL SUPPORT  
SPRING  
1/4" to 1" NPT THREAD  
HEAVEY-DUTY RADIAL RIVET CRIMP

Grease Fitting

Carefully remove the safety cap of the lower drain grease fitting. Contact your local Cameron's Valves & Measurement group representative for further assistance, if needed. Back out the stinger of the pressure releasing tool until it stops. Install the pressure releasing tool onto the uncapped grease fitting. Carefully screw the stinger of the releasing tool- (until the ball check in the grease fitting is pushed off its seat). This will allow the valve to drain or to release body pressure. After completion, back out the stinger of the pressure releasing tool to allow the ball check in the grease fitting to reseat and permit easy removal of the pressure releasing tool. Replace safety cap on the lower drain grease fitting.

### Low Temperature Precautions

Prior to exposure to freezing temperatures it is highly recommended the valve be drained. Water that may be trapped in the body cavity could freeze and impair the operation of the valve or damage the valve. If the valve has a grease fitting in the lower drain, a sufficient amount of anti-freeze injected into the body cavity via the lower drain grease fitting will prevent accumulated water from freezing.

It is also advisable to inject a sufficient amount of valve lubricant into the grease fittings of valve and operator (if present) prior to extended cold temperature exposure.

Trapped water should be drained from stem extensions. Some stem extensions in the field are equipped with plastic plugs that can be removed to drain trapped water from the piped extension.

**Low Temperature Precautions** Continued

**Volume of Anti-freeze (Ethylene Glycol) to Prevent Freezing**

Minimum Expected Temperature Valve (Percent Anti-freeze)	18°F (-8°C) (18%)	13°F (-11°C) (23%)	7°F (-14°C) (28%)	-8°F (-22°C) (37%)	-28°F (-33°C) (48%)
2" 150-300	0.1 gallons (0.5 Liters)	0.2 gallons (0.7 Liters)	0.2 gallons (0.8 Liters)	0.3 gallons (1.1 Liters)	0.4 gallons (1.5 Liters)
2" 600-2500	0.3 gallons (1 Liters)	0.3 gallons (1.3 Liters)	0.4 gallons (1.6 Liters)	0.6 gallons (2.1 Liters)	0.7 gallons (2.7 Liters)
2-1/2" 150-300	0.2 gallons (0.6 Liters)	0.2 gallons (0.8 Liters)	0.3 gallons (1 Liters)	0.3 gallons (1.3 Liters)	0.4 gallons (1.6 Liters)
2-1/2" 400-2500	0.3 gallons (1 Liters)	0.3 gallons (1.3 Liters)	0.4 gallons (1.6 Liters)	0.6 gallons (2.1 Liters)	0.7 gallons (2.7 Liters)
3" 150-300	0.2 gallons (0.7 Liters)	0.2 gallons (0.9 Liters)	0.3 gallons (1.1 Liters)	0.4 gallons (1.4 Liters)	0.5 gallons (1.8 Liters)
3" 600-2500	0.4 gallons (1.4 Liters)	0.5 gallons (1.7 Liters)	0.6 gallons (2.1 Liters)	0.7 gallons (2.8 Liters)	1 gallons (3.6 Liters)
4" 150-300	0.5 gallons (1.7 Liters)	0.6 gallons (2.2 Liters)	0.7 gallons (2.6 Liters)	0.9 gallons (3.5 Liters)	1.2 gallons (4.5 Liters)
4" 600-2500	0.5 gallons (2 Liters)	0.7 gallons (2.6 Liters)	0.8 gallons (3.2 Liters)	1.1 gallons (4.2 Liters)	1.4 gallons (5.5 Liters)
6" 150-300	1 gallons (3.8 Liters)	1 gallons (3.7 Liters)	1.2 gallons (4.5 Liters)	1.6 gallons (5.9 Liters)	2 gallons (7.6 Liters)
6" 600-2500	1 gallons (3.8 Liters)	1.2 gallons (4.4 Liters)	1.4 gallons (5.3 Liters)	1.9 gallons (7 Liters)	2.4 gallons (9.1 Liters)
8" 150-300	1.7 gallons (6.5 Liters)	2.2 gallons (8.4 Liters)	2.7 gallons (10.2 Liters)	3.6 gallons (13.4 Liters)	4.6 gallons (17.4 Liters)
8" 600-2500	1.8 gallons (6.8 Liters)	2.3 gallons (8.7 Liters)	2.8 gallons (10.6 Liters)	3.7 gallons (14 Liters)	4.8 gallons (18.2 Liters)
10" 150-300	2.7 gallons (10.2 Liters)	3.5 gallons (13.1 Liters)	4.2 gallons (15.9 Liters)	5.6 gallons (21 Liters)	7.2 gallons (27.3 Liters)
10" 600-2500	2.7 gallons (10.2 Liters)	3.5 gallons (13.1 Liters)	4.2 gallons (15.9 Liters)	5.6 gallons (21 Liters)	7.2 gallons (27.3 Liters)
12" 150-300	4.5 gallons (17.0 Liters)	5.8 gallons (21.8 Liters)	7 gallons (26.5 Liters)	9.3 gallons (35 Liters)	12 gallons (45.4 Liters)
12" 600-2500	4 gallons (15 Liters)	5.1 gallons (19.2 Liters)	6.2 gallons (23.3 Liters)	8.1 gallons (30.8 Liters)	10.6 gallons (40 Liters)
14" 150	3.6 gallons (13.6 Liters)	4.6 gallons (17.4 Liters)	5.6 gallons (21.2 Liters)	7.4 gallons (28 Liters)	9.6 gallons (36.3 Liters)
14" 300-1500	5.4 gallons (20.4 Liters)	6.9 gallons (26.1 Liters)	8.4 gallons (31.8 Liters)	11.1 gallons (42 Liters)	14.4 gallons (54.5 Liters)
16" 150	5 gallons (19.1 Liters)	6.4 gallons (24.4 Liters)	7.8 gallons (29.7 Liters)	10.4 gallons (39.2 Liters)	13.4 gallons (50.9 Liters)
16" 300-2500	7.4 gallons (27.9 Liters)	9.4 gallons (35.7 Liters)	11.5 gallons (43.5 Liters)	15.2 gallons (57.4 Liters)	19.7 gallons (74.5 Liters)

**Low Temperature Precautions** Continued

**Volume of Anti-freeze (Ethylene Glycol) to Prevent Freezing**

Minimum Expected Temperature Valve (Percent Anti-freeze)	18°F (-8°C) (18%)	13°F (-11°C) (23%)	7°F (-14°C) (28%)	-8°F (-22°C) (37%)	-28°F (-33°C) (48%)
18" 150	6.5 gallons (24.5 Liters)	8.3 gallons (31.3 Liters)	10.1 gallons (38.2 Liters)	13.3 gallons (50.4 Liters)	17.3 gallons (65.4 Liters)
18" 300-1500	9.9 gallons (37.5 Liters)	12.7 gallons (47.9 Liters)	15.4 gallons (58.3 Liters)	20.4 gallons (77 Liters)	26.4 gallons (99.9 Liters)
20" 150	8.3 gallons (31.3 Liters)	10.6 gallons (40 Liters)	12.9 gallons (48.8 Liters)	17 gallons (64.4 Liters)	22.1 gallons (84 Liters)
20" 300-900	12.4 gallons (47 Liters)	15.9 gallons (60.1 Liters)	19.3 gallons (73.1 Liters)	25.5 gallons (96.6 Liters)	33.1 gallons (125 Liters)
22" 150	13.1 gallons (49.7 Liters)	16.8 gallons (63.6 Liters)	20.4 gallons (77.4 Liters)	27 gallons (102 Liters)	35 gallons (133 Liters)
22" 300-600	14.8 gallons (55.9 Liters)	18.9 gallons (71.4 Liters)	23 gallons (86.9 Liters)	30.3 gallons (115 Liters)	39.4 gallons (149 Liters)
24" 150	13 gallons (49.1 Liters)	16.6 gallons (62.7 Liters)	20.2 gallons (76 Liters)	26.6 gallons (101 Liters)	34.6 gallons (131 Liters)
24" 300-900	18 gallons (68.1 Liters)	23 gallons (87.1 Liters)	28 gallons (106 Liters)	37 gallons (140 Liters)	48 gallons (182 Liters)
26" 150	16.7 gallons (63.4 Liters)	21.4 gallons (81 Liters)	26 gallons (99 Liters)	34.4 gallons (130 Liters)	44.6 gallons (169 Liters)
26" 300-600	22.5 gallons (85.2 Liters)	28.8 gallons (109 Liters)	35 gallons (132 Liters)	46.3 gallons (175 Liters)	60 gallons (227 Liters)
28" 150	21.2 gallons (80 Liters)	27.1 gallons (103 Liters)	33 gallons (125 Liters)	43.7 gallons (165 Liters)	56.6 gallons (214 Liters)
28" 300-600	27.7 gallons (105 Liters)	35.4 gallons (134 Liters)	43.1 gallons (163 Liters)	57 gallons (216 Liters)	73.9 gallons (280 Liters)
30" 150	25.9 gallons (98 Liters)	33.1 gallons (125 Liters)	40.3 gallons (153 Liters)	53.3 gallons (202 Liters)	69.1 gallons (262 Liters)
30" 300-600	34.6 gallons (131 Liters)	44.2 gallons (167 Liters)	53.8 gallons (204 Liters)	71 gallons (269 Liters)	92.2 gallons (349 Liters)
32" 150	26.4 gallons (100 Liters)	34 gallons (128 Liters)	41 gallons (155 Liters)	54 gallons (205 Liters)	70 gallons (267 Liters)
32" 300-600	49.7 gallons (188 Liters)	63 gallons (240 Liters)	77 gallons (293 Liters)	102 gallons (387 Liters)	132 gallons (502 Liters)
34" 150	30.4 gallons (115 Liters)	39 gallons (147 Liters)	47 gallons (179 Liters)	62 gallons (237 Liters)	81 gallons (307 Liters)
34" 300-600	63.2 gallons (239 Liters)	81 gallons (306 Liters)	98 gallons (372 Liters)	130 gallons (492 Liters)	169 gallons (638 Liters)
36" 150	28.4 gallons (108 Liters)	36 gallons (138 Liters)	44 gallons (167 Liters)	58 gallons (221 Liters)	76 gallons (287 Liters)
36" 300-600	96.3 gallons (365 Liters)	123 gallons (466 Liters)	150 gallons (567 Liters)	198 gallons (749 Liters)	257 gallons (972 Liters)
40" 150	44.3 gallons (168 Liters)	57 gallons (214 Liters)	69 gallons (261 Liters)	91 gallons (345 Liters)	188 gallons (448 Liters)
40" 300-600	130 gallons (494 Liters)	167 gallons (631 Liters)	203 gallons (768 Liters)	268 gallons (1015 Liters)	348 gallons (1317 Liters)

**Low Temperature Precautions** Continued

**Volume of Anti-freeze (Ethylene Glycol) to Prevent Freezing**

Minimum Expected Temperature Valve (Percent Anti-freeze)	18°F (-8°C) (18%)	13°F (-11°C) (23%)	7°F (-14°C) (28%)	-8°F (-22°C) (37%)	-28°F (-33°C) (48%)
42" 150	49.7 gallons (188 Liters)	63 gallons (240 Liters)	77 gallons (292 Liters)	102 gallons (386 Liters)	132 gallons (501 Liters)
42" 300-600	166 gallons (629 Liters)	212 gallons (803 Liters)	258 gallons (978 Liters)	341 gallons (1292 Liters)	443 gallons (1677 Liters)
48" 150	67.7 gallons (256 Liters)	87 gallons (328 Liters)	105 gallons (399 Liters)	139 gallons (527 Liters)	181 gallons (684 Liters)
48" 300-600	343 gallons (1297 Liters)	438 gallons (1658 Liters)	533 gallons (2018 Liters)	704 gallons (2667 Liters)	914 gallons (3459 Liters)

**Lubricating Handwheel and Operator Assembly**

**Handwheel Operated Valves-**

Connect a grease gun containing NLGI grade 2 petroleum base grease to the 1/8" Alemite type grease fitting on the bearing housing. Pump in a small amount of grease. DO NOT OVERFILL.

**Bevel Gear Operators-**

Bevel gear operators are supplied by other manufacturers. Consult particular manufacturer's instructions. If these are not available, lubricate the same as Handwheel Operated Valves above.

**Motor Operated Valves-**

Motor operators are supplied by other manufacturers. Consult particular manufacturer's instructions.

**Lubricating Seats**

(6" and larger valves equipped with seat sealant ports). Lubricate once a year.

1. Only use grease guns that are equipped with a pressure gage.
2. Some seat sealants become very stiff or viscous in cold weather. It may be difficult to pump some sealants under these conditions. It is recommended that the grease gun be kept in a heated area until it is ready to be used. If this is not possible, contact your local Cameron Valves & Measurement group representative for low temperature sealant recommendations.
3. Move the valve to the closed position.
4. Carefully, remove the safety caps on the seat lubrication fitting using a wrench.

## Lubricating Handwheel and Operator Assembly Continued

**WARNING:** Back up the seat grease fitting using a wrench so only the safety cap will be removed from the fitting. Carefully remove the safety cap from the seat grease fitting. NEVER remove the grease fitting with the valve under pressure!

5. Connect the grease gun to the seat lubrication fitting(s). (Both sets may be lubricated at the same time).
6. Pump the sealant into the seat. Once the pressure rises above the valve rated pressure, hold for three (3) minutes to promote filling of the grease grooves.

**Note:** Grease guns can develop pressures far in excess of the valve working pressure. Use only grease guns, which are equipped with pressure gages. Do not exceed the valve maximum allowable working pressure.

7. Stroke the valve to spread the sealant on the seat surfaces. (Indicator rod should move approximated 1" or 25 mm).
8. Release the pressure in the grease gun and remove it from the grease fitting. The fitting ball check should prevent the release of the valve grease pressure.
9. Install the fitting safety cap and tighten securely.
10. Repeat for the other seat. Both seats may be lubricated at the same time, if desired.

### Recommended Lubricants and Sealants

TRIM	NORMAL SEAT LUBRICANT	EMERGENCY SEAT SEALANT	BEARING LUBRICANT	STEM PACKING
<b>T-11, T-102</b> (Aromatic Hydrocarbons and refined products)	WKM #58G or Val-Tex 700	WKM #58G	NLGI Grade 2 Bearing grease	WKM #113 or Jim Ray Tiger Pak "FF"
<b>T-10, T-24</b> (Sour Oil and Gas, Waterflood)	Val-Tex700	WKM #102	NLGI Grade 2 Bearing grease	WKM #109
<b>T-50, T-51</b> (Geothermal water and steam)	NONE	NONE	NLGI Grade 2 Bearing Grease	WKM #115
<b>Trim T-36, T-37, T-38, T-39</b> (Low temperature produced hydrocarbons)	Val-Tex 50	WKM #103	WKM #1	WKM #109
<b>T-88</b> (Anhydrous Ammonia Products)	NLGI Grade 2 Bearing grease or Chemola TF-41 or Val-Tex 80H	NLGI Grade 2 Bearing grease or Chemola TF-41 or Val-Tex 80H	NLGI Grade 2 Bearing grease	Jim Ray Tiger Pak "A"



**Lubricating Handwheel and Operator Assembly** *Continued*

PRODUCT	MANUFACTURER
WKM 1 WKM 58G WKM 102 WKM 103 WKM 109 WKM 113 WKM 115	<b>Cameron Valves &amp; Measurement CAMSERV™ Aftermarket Services</b> 8820 Meldrum Ln Houston, TX 77075 713-946-2122 Fax: 713-331-5813
Val-Tex 700 Val-Tex 50	<b>Val-Tex</b> 10600 Fallstone Road Houston, TX 77009 800-627-9771 281-530-4848 Fax: 281-530-5225
Jim Ray Tiger Pak FF Jim Ray Tiger Pak A	<b>Jim Ray</b> 10645 Richmond Ave. #130 Houston TX 77042 713-785-5055 Fax: 713-785-5534

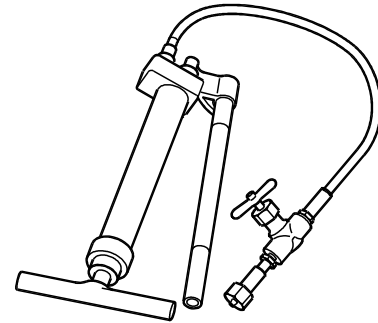

Figure 10 - Screw/Prime Hand Gun, Part Number 2122495-01. Exact configuration may vary from illustration.

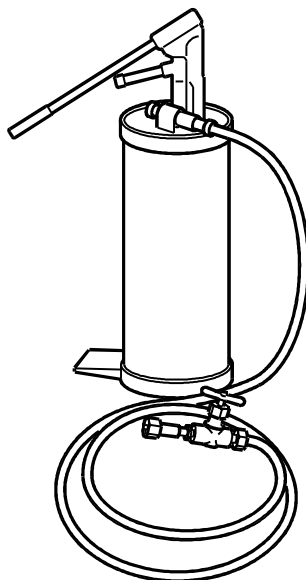

Figure 11 - Bucket-Type Gun, Cameron Part Number K065189. Exact configuration may vary from illustration.

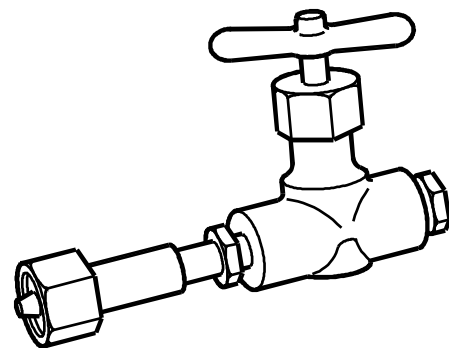

Figure 12 - Adapter Fitting, Part Number K296434

## Maintaining Vee-Packing

(If so equipped) - Once a year or more often as required.

1. Valves equipped with Vee Packing may require periodic inspection and maintenance to preclude stem leakage. This is particularly important if the valves are in service at temperatures above 250°F (121°C).
2. Other designs use a self-adjusting stem seal identified by the following tag on the packing fitting. These require only periodic inspection.
3. Inspect the valve for evidence of stem leakage.



This might be determined by paint discoloration around the bonnet-yoke tube joint. If there is no evidence of leakage, no maintenance is required. It is often beneficial to add one stick of packing once a year to help keep the packing pliable and prevent future problems. (Couple of "sticks" for larger valves).

4. If leakage is evident, inject plastic packing as follows:

Stick Method	Gun Method
<p><b>Note:</b> Packing is not damaged by cold. However, keep plastic packing in a warm place (like a heated room or vehicle cab) until ready for use to keep pliable</p>	
<ul style="list-style-type: none"> <li>• Remove the injection stinger from the packing fitting. <b>CAUTION:</b> pressure may be trapped in the packing box</li> <li>• Apply a good grade of earing grease to the threads</li> <li>• Place a stick of packing into the fitting and screw in the stinger until it seats</li> <li>• Repeat as necessary. Use screw torques as follows:               <ul style="list-style-type: none"> <li>• 3-4 ft-lb (40-50 in-lb, 4-5.5 N-m) for WKM packings</li> <li>• 4-5 ft-lb (50-60 in-lb, 5.5-7 N-m) for thick packings</li> <li>• Do not exceed 7 ft-lb (60 in-lb, 9.5 N-m) as this may exceed the 10,000 psig (689 barg) rating of the fitting</li> </ul> </li> <li>• Back out the screw until the threads show. This allows the bail check to seat</li> </ul> <p><b>CAUTION: Apply only enough packing to stop the leak</b></p>	<ul style="list-style-type: none"> <li>• Remove the injection stinger from the packing fitting. <b>CAUTION:</b> pressure may be trapped in the packing box</li> <li>• Assemble the packing gun with the appropriate plastic packing</li> <li>• Connect the gun to the packing fitting</li> <li>• Apply 5500-7500 psi (379-517 bar) to the packing gun. Thick packings may require 8000-9000 psi (551-620 bar) <b>CAUTION:</b> The WKM style packing gun applies twice the hand pump pressure</li> <li>• Hold for several minutes</li> <li>• Add more plastic if the pressure drops</li> <li>• Repeat until the packing pressure holds steady</li> <li>• Do not exceed 10,000 psi (689 bar)</li> <li>• Remove the packing gun</li> <li>• Dig out any excess packing from the packing fitting</li> <li>• Apply a small amount of bearing grease to the packing fitting screw</li> <li>• Install the packing fitting screw and tighten</li> </ul>

## Troubleshooting

Trouble	Probable Cause	Remedy
The Grease fitting or bleed plug is leaking.	The safety cap or bleed plug screw is loose.	Tighten the safety cap or bleed plug screw.
The valve is leaking around bonnet to body joint.	The bonnet seal is leaking.	Ensure that the bonnet nuts are tightened properly. Call CAMERON VALVES & MEASUREMENT group representative if leakage persists.
A restriction is present in the valve bore.	The gate is not properly aligned with the seats.	<b>HANDWHEEL OR BEVEL GEAR OPERATED VALVES:</b> Open the valve fully by turning the handwheel counter-clockwise. Tighten securely. <b>DO NOT BACK OFF THE HANDWHEEL.</b> <b>MOTOR OPERATED VALVES:</b> Make sure the operator limit switches are set correctly.
The valve is hard to operate.	The lubrication is not sufficient.	Lubricate the bearings, operator, and/or seats per the Routine Maintenance Section. Lubricate the operator per the manufacturer's instructions.
	Ice is present in the yoke tube, handwheel unit, or operator. (Pipeline bending moments distorting the valve body).	Apply heat to melt ice.
	Line bind is present. (Pipeline bending moments distorting the valve body).	Relieve the bind or moment on the valve.
Motor operator will not actuate the valve.	Improperly sized motor operator.	Replace with properly sized motor operator.
	Improperly wired electric operator.	Verify wiring following instructions and schematics provided by the operator manufacturer.
Valve operation is erratic.	The bearings need lubrication.	Lubricate bearings per the Routine Maintenance Section.
	The bearing or gear unit is broken or damaged.	Replace broken or damaged parts.
The valve seats will not seal.	Valve is not fully closed.	Fully close the valve. Turn the handwheel <b>CLOCKWISE</b> .
	Seat or seat seals are damaged.	Lubricate seats per Routine Maintenance Section. Replace parts.

Contact your Cameron's Valves & Measurement group representative for a Repair Manual



For the most current contact and location information go to: [www.c-a-m.com/valvesandmeasurement](http://www.c-a-m.com/valvesandmeasurement)

© Cameron's Valves & Measurement Group Printed in Canada 07/09-ION-2M IOM-WKM-GATE-SAF-T-SEAL

Rev. 1 07/09